

IMPORTANT

BEFORE --- Installing/Re-Installing to the door

- * TEST YOUR CODE NUMBER
- * PREFIXED BY 'C' TO CLEAR
- * THEN TURN THE HANDLE

- Now you have changed your code
- Tested your Lock
- Install/Refix the Lock to the door
- Ensuring the right hand of opening (left or right) and position of the spindle, as described in the Installation Instructions.

KEEP THIS INSTRUCTION MANUAL -
YOU WILL NEED IT AGAIN IE.
"WHEN CHANGING YOUR CODE NUMBER"

(PRINTED IN JAPAN)

DIGITAL DOOR LOCK

MECHANICAL COMBINATION ACCESS
CONTROL DOOR LOCK

1100 SERIES

'USERS' INSTALLATION & INFORMATION MANUAL

IT IS IMPORTANT TO UNDERSTAND
THE OPERATION OF YOUR DIGITAL DOOR LOCK
TO MAINTAIN A CONTINUED SMOOTH AND
TROUBLE FREE PERFORMANCE. REMEMBER

"THIS IS NO ORDINARY DOOR LOCK"
THEREFORE ALL THE POINTS LAYED OUT IN
THIS MANUAL ARE IMPORTANT.

SO PLEASE
READ ALL THE INSTRUCTIONS
AND FOLLOW THEM CAREFULLY.

—KEEP THIS MANUAL YOU WILL
NEED IT AGAIN—

INSTALLATION & CODE CHANGE INSTRUCTIONS

ENCLOSED PARTS (PARTS LIST)

NO.	NAME OF PARTS	CONTENT
1.	OUTSIDE BODY, WITH LEVER HANDLE	1 PCE
2.	INSIDE BODY, WITH LEVER HANDLE	1 PCE
3.	RUBBER ESCUTCHEON	2 PCS
4.	CASE LATCHBOLT	1 PCE
5.	LATCHBOLT FACE PLATE	1 PCE
6.	STRIKE-PLATE	1 PCE
7.	MORTICE STRIKER-BOX	1 PCE
8.	SPINDLE	1 PCE
9.	SUPPORT PIN	1 PCE
10.	WOOD SCREWS (8 x 16)	4 PCS
11.	MACHINE SCREWS (5 x 55)	4 PCS
12.	MACHINE SCREWS (5 x 45)	4 PCS
13.	TWEEZERS	1 PCE
14.	KEY TUMBLER (RED) .. CODE	1 PCE
15.	KEYLESS TUMBLER (BLUE) .. NON-CODE	1 PCE
16.	CARD FOR "SECRET NUMBER (CODE NUMBER)"	1 PCE

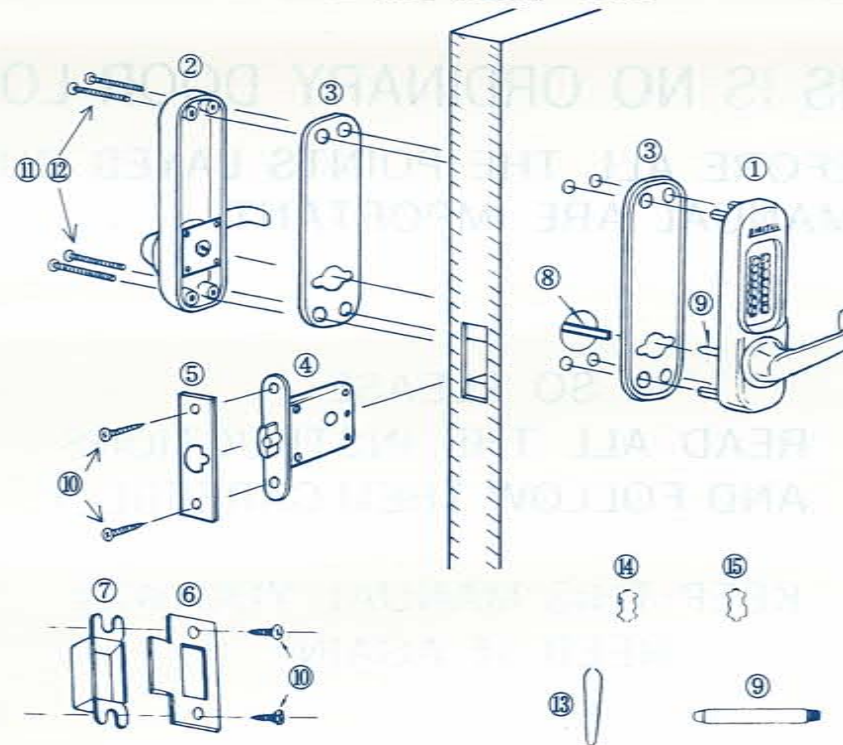

1

INSTALLING YOUR DIGITAL DOOR LOCK

- I. 1. Taking the Template provided.
2. Decide on the position for your Digital Door Lock.
3. Drill holes as per the Template.

IMPORTANT : To ensure trouble free operation, the holes **MUST** be drilled accurately.

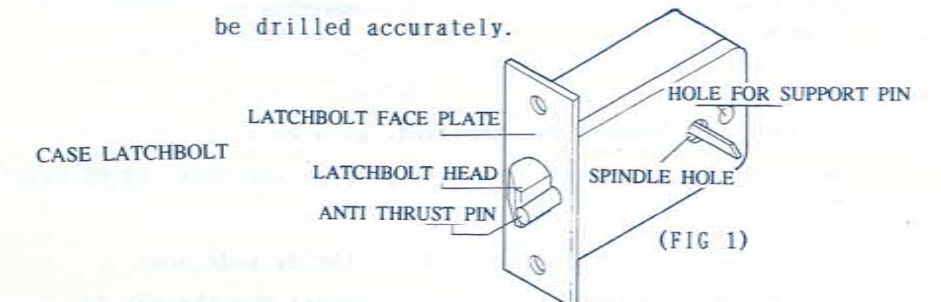

- II. 1. Insert the Latchbolt into the mortice hole, scribe a line around the Latchbolt face plate and remove it.
2. Chisel out the scribed space until the Latchbolt face plate is flush with the surface of the door edge.
3. Fasten Latchbolt with the wood screws.

IMPORTANT : Ensure that the Latchbolt face plate is **EVENLY** fitted. (DO NOT bend the face plate by tightening more at the top or bottom.)

- III. 1. **BREAK** the spindle according to the door thickness.

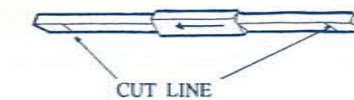

2. Insert the spindle from the **RIGHT**, on the position that you see the 'LATCHBOLT HEAD', according to the direction of the "ARROW" on the spindle, through the door into the spindle hole of latchbolt.

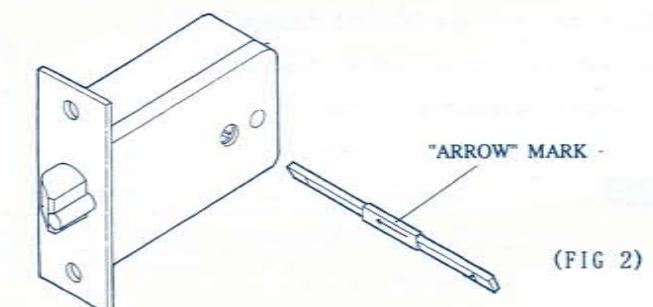

2

IMPORTANT : Spindle MUST lay at an angle toward the latchbolt head and edge of door. (see FIG 3)

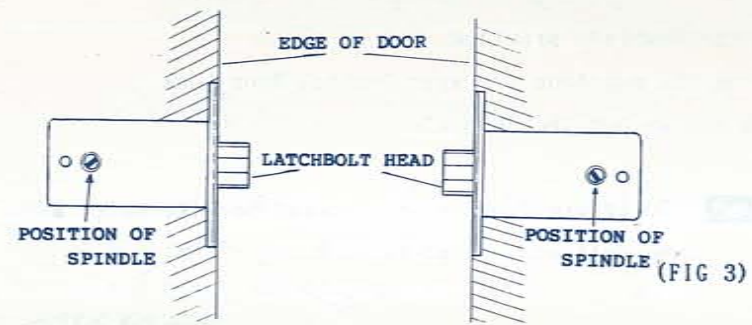

- IV. 1. Install the Support Pin provided, at a hole of the direction where the lever handle is installed, on the backside of outside body.
2. Fit Rubber Escutcheon provided, to the Outside Body.
3. Insert the 4-Hexagonal Posts and Support Pin through the holes.

(see FIG 4)

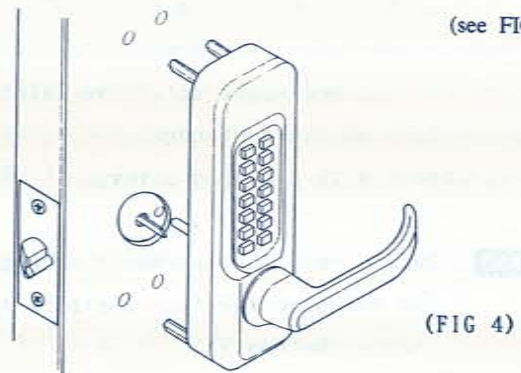

IMPORTANT : Ensure that the spindle was inserted to the Spindle Hole of the outside body, correctly.

- V. 1. Fit the second Rubber Escutcheon to the Inside Body.
2. Fit the inside body over the spindle from exit side of door making sure the spindle remains laying at an angle toward the Latchbolt face and edge of door. (see FIG 3)

- VI. 1. Select the machine screws and fasten them through the inside body, door and outside body - making sure they are not to loose or to tight. (see FIG 5)

IMPORTANT : Check the operation of the latchbolt by turning the inside handle.

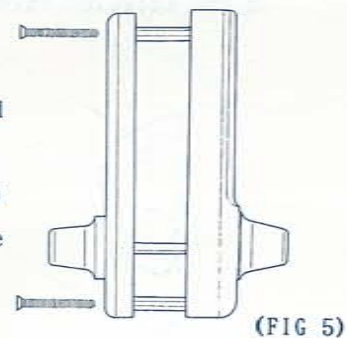

- VII. 1. Close the door to determine the correct position where the Latchbolt Head touches the face of the door jamb and mark out.
2. Chisel out for the Mortice Strike Box and for the Strike Plate so that it is flush with the surface of the door jamb.
3. Fasten Strike Plate with wood screws.

BEFORE CLOSING THE DOOR -- TEST THE OPERATION OF THE DIGITAL DOOR LOCK

- a) Refer to the card showing your code number.
- b) Enter your code number -- PREFIXED BY 'C'.
- c) Turn the outside handle.
- d) Let go of handle and latch will return to locked position.

IMPORTANT : Make sure that when the

door is in the closed/locked position, the Latchbolt Head only inserts into the Strike Box in door jamb and NOT the Anti Thrust Pin. (FIG 6)

((The Anti Thrust Pin is retracted by pushing against the Strike Plate to deadlock the Latchbolt.))

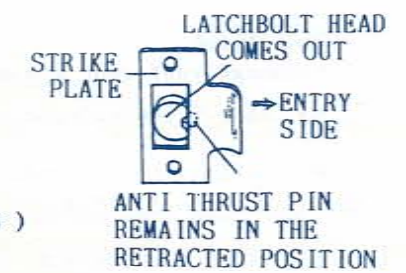

(FIG 6)

HOW TO USE PASSAGE FUNCTION

** TO ENGAGE, PUSH "C" TO CLEAR THEN THE 'PASSAGE BUTTON', AND THEN YOUR SECRET CODE NUMBER.

TO CLEAR THE PASSAGE FUNCTION

** PRESS THE 'PASSAGE BUTTON', THEN "C" TO CLEAR.

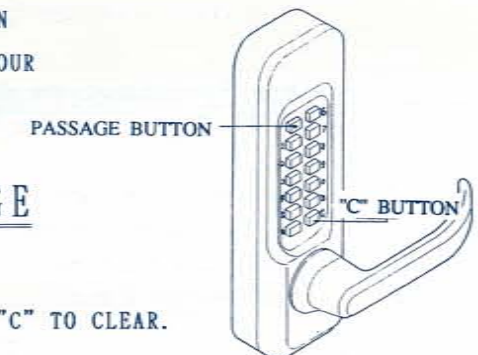

MAINTENANCE

AS LONG AS YOUR DIGITAL DOOR LOCK HAS BEEN INSTALLED, ACCURATELY, AND IS USED CORRECTLY, IT SHOULD BE VIRTUALLY MAINTENANCE FREE. IT IS A GOOD IDEA TO PERIODICALLY USE A NON-GREASY LUBRICANT ON THE LATCHBOLT FACE, INTERNAL AND EXTERNAL HANDLE.

CODE CHANGE INSTRUCTIONS

BEFORE Attempting to change your code number, please read this information carefully - then follow the step by step instructions using the diagrams as a guide.

RED TUMBLERS : CODE
 BLUE TUMBLERS : NON-CODE
 " C " TUMBLER : FOR CLEAR, CANNOT BE REMOVED
 WHITE TUMBLER : FOR PASSAGE FUNCTION, IF REMOVED, PASSAGE FUNCTION DOES NOT WORK.
 DO NOT REPLACE WITH ANY OTHER TUMBLER.

Although your code group number is not sequential, there are a possible 5,500 code possibilities.

When changing your code number, it is VERY IMPORTANT that ALL the 'code' and 'non-code' tumblers are replaced CORRECTLY. - if 1 or more of your code/non-code tumblers are replaced INCORRECTLY, your lock will NOT work and it may damage the lock.

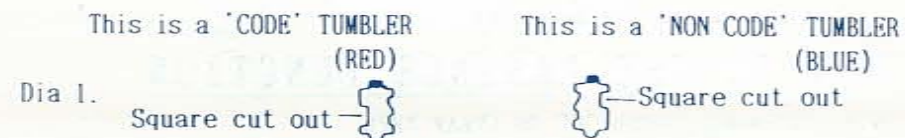

EACH is COLOURED at the TOP end - EACH has a SQUARE CUT OUT on ONE SIDE ONLY. (see Dia 1)

The code/non code tumblers are positioned in the Lock so that the

- Coloured top end is facing upwards
- Square cut out is facing the nearest outside edge of the Lock body as shown below

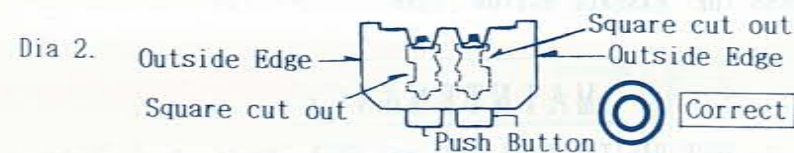

So when you change your code number, ALWAYS remember to replace the code/non code tumblers in the CORRECT positions as shown Dia 2. and not the incorrect positions as shown in Dia 3.

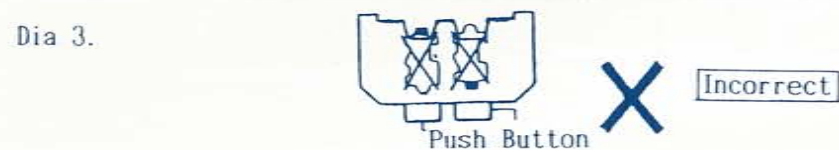

HOW TO CHANGE THE CODE NUMBER

Remove your Digital Door Lock from the box or door.

Hold the outside body in the horizontal position. remove the 4 red screws. and carefully remove the plate.

PAY ATTENTION FOR HANDLING THE LID AS IT IS INSTALLED THE MANY SPRINGS AT THE INSIDE OF THE LID

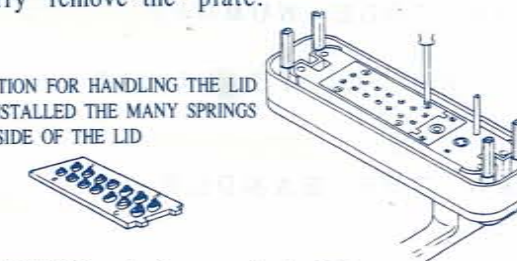

*Decide on the code group number you wish to use.

HOW TO REMOVE code/non code tumblers
 -Still holding the Lock in the horizontal position PRESS the C button in from underneath, continue pressing in the C button until you have COMPLETED the code change.

Using the tweezers provided lift out the code/non code tumblers you wish to change NEVER attempt to remove the C tumbler.

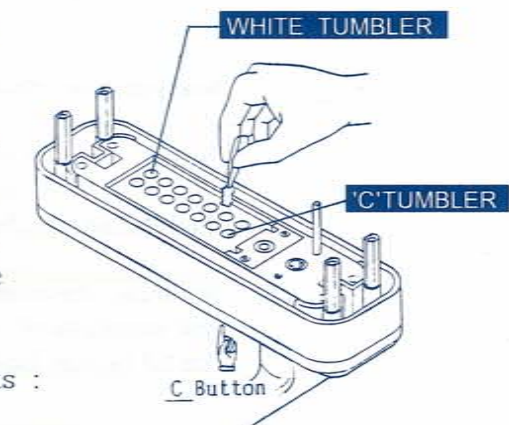

REMEMBER - To increase the number of digits :
 Add more red 'code' tumblers.
 - To decrease the number of digits :
 Add more blue 'non code' tumblers. *Press in the C Button

DO NOT REMOVE A C-TUMBLER AND A WHITE TUMBLER, ABSOLUTELY.

HOW TO REPLACE code/non code tumblers

-Still pressing in the C button.
 -Insert the red code tumblers to form your new code.
 -Insert the blue 'non code' tumblers into the remaining spaces.

REMEMBER : It is important that
 -The coloured top end is facing upwards.
 -The square cut out is facing the nearest outside edge of the Lock body.

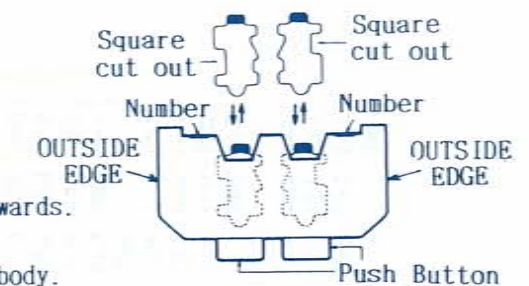

** Release the C button and replace the plate carefully, using the 4 red screws.